



VT801 Specification Sheet

SERIES VT801
SUBJECT Technical Information and Data

VT801 SWEEPER

Sheet 1 of 2
Revision Number: 02-14
Date: 02/20/2014
Reference: JNA 022014

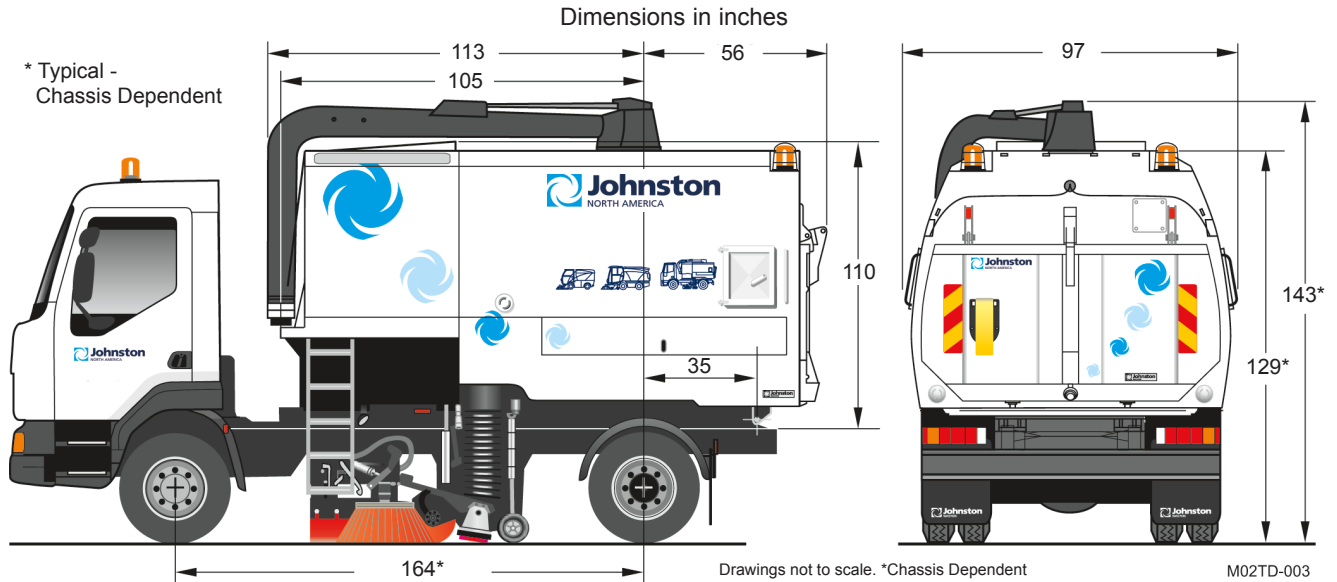

Data and Performance Information

Capacities	
Hopper voided volume	10.5 yd ³ nominal
Fuel tank	50 gallons
Water tank	534 gallons
Hydraulic system	20 gallons

Engine Data	
Model	John Deere 4045 HF285
Cubic capacity	4.5 litres
No. of cylinders	4
Gross rated power	115 Hp
Maximum torque	406 ft/lbs @ 1500 rpm
Legislation compliance	US EPA Tier 3b
Operational rpm	Variable 1200-1500 & 1500-2000 rpm
Sump capacity	3 gallons
Ambient temperature	120°F worldwide approval
Cold start capability	-4°F

Sweeping Equipment	
Gutter Broom (GB)	28 inches
Wide Sweep Brush (WSB)	16 in x 50 in
GB life expectancy	80 accumulated working hours
WSB life expectancy	150 accumulated working hours
Nozzle trunking diameter	10 inch I.D.
Nozzle width	30 inches

General Data	
Chassis requirement	33,000-36,000 lbs
Wheelbase	164" - 182" chassis dependent
Discharge height	42 in (nom) chassis dependent
Discharge angle	56° nominal
Door opening angle	125° nominal
Hopper screen area	18.3 ft ²
Water pump output	Up to 9 gal/min
Water pump pressure	50.75 psi
Hydraulic suction filtration	125 micron
Hydraulic return filtration	25 micron
Hydraulic pump displacement	Max output 7 gal
Sweeping speeds	2-10 mph (chassis dependent)

Johnston North America Inc.
606 A&B Performance Road • Mooresville, NC 28115
Tel: 704.658.1333 Fax: 704.658.1377
E-mail: info@johnstonnorthamerica.com • johnstonnorthamerica.com





VT801 Specification Sheet

Technical Specification

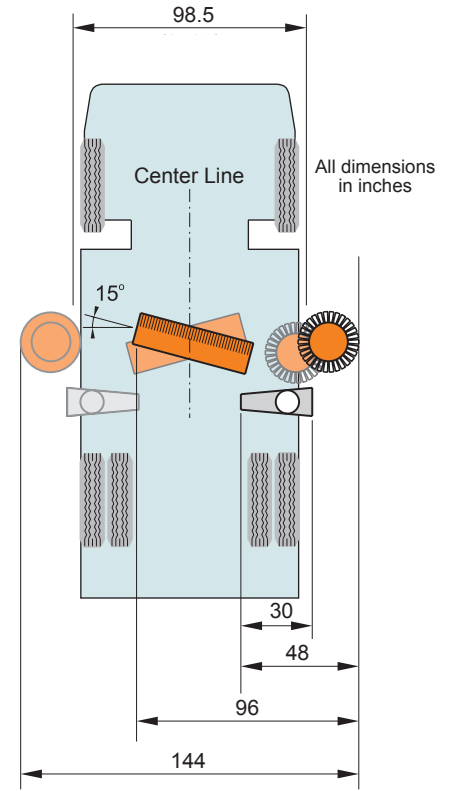
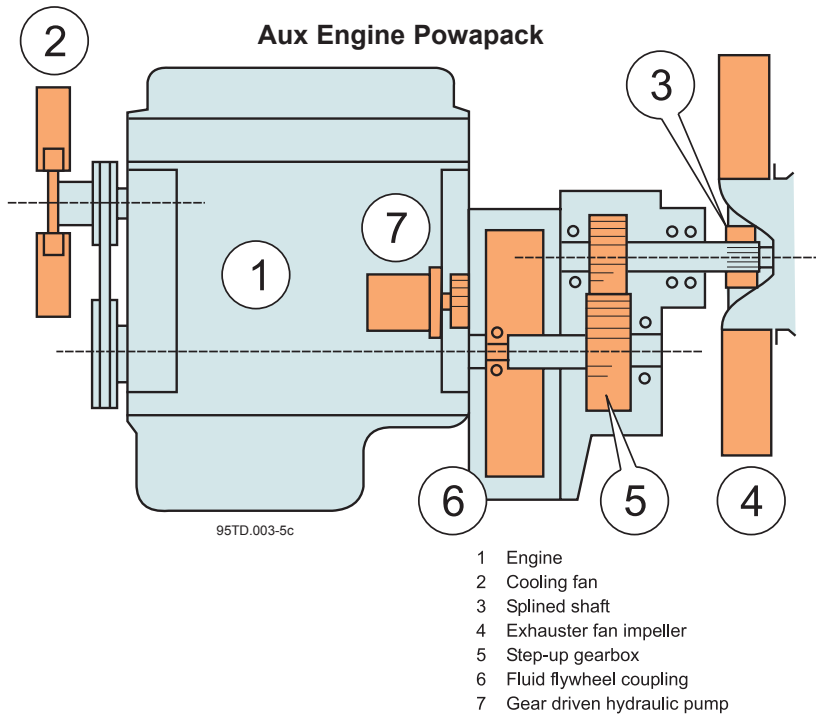

Simultaneous channel brush option 95TD.004-5c

Base Specification

Performance Data

Exhauster Fan:

Operational speed variable between 2400 rpm - 3500rpm to suit operation. Driven from the auxiliary engine via step-up gearbox and fluid flywheel coupling.

Step-up gearbox ratio: 1.79:1

Gutter Broom:

Quick release brush system with infinitely variable speed up to 200rpm (cab controlled).

Nozzle:

H.D. alloy constructed rubber lined cast aluminium nozzle with 10 in I.D. inlet and tool free adjustment.

Wide Sweep Broom:

Quick release brush system with a nominal 160rpm rotation speed.

Dust suppression system:

Dust suppression sprays located at suction nozzle (4), gutter broom (4) and across front of vehicle (4).

Pressadrain water purging system.

Electrical system:

12 Volt.

All external loom connections are certified waterproof & dust proof IP67 rated.

Controls:

Center cab mounted master control panel with Johnston Video Monitor (JVM) providing information on a wide range of sweeper functions plus data capture download. Up to

four optional cameras can also be viewed on the JVM screen. Separate palm rest controller for the main sweeping functions is mounted on the door side.

In cab noise:

<68 dB(A) generally (dependent on chassis selection).

Exterior noise / Sound power level:

L_{WA} 79 dB(A) for standard power engines measured in accordance with EC directive 2000/14/EC.

Body & Cowl

Body comprises of hopper & integral water tank. Fabricated from heavy duty 9 gauge stainless steel plate.

Cowling is lined with 1^{1/4}" soundproofing material.

Water tank incorporates anti-surge baffles and filled via a type 'A' water hydrant fill. A H.D. twin diaphragm pump runs continuously and is able to run dry. Water tight twin lock rear door latching system with de-watering function. Two body side access doors.

Plug in hopper floor as transfer port for use as street flusher.

Rear discharge chute, twin rear caged beacons, automatic multi position body propping mechanism and side storage lockers are standard features.

Optional equipment

- JCB Ecomax 444 NRMM Tier 4 125 Hp @ 2200 rpm. Max torque 324.5 ft/lbs @ 1300 rpm.
- Camera monitoring system.
- In-Cab Gutter Broom Lateral Control.
- PM10 dust suppression system.
- In-Cab Gutter Broom Tilt Control.
- Pneumatic hopper screens.
- Powascrub - In-Cab wide broom down pressure control.
- Supawash - high pressure washing system 8.5 gal/min @ 1500 psi. Hand lance, hose reel, front and nozzle spraybars.
- 8" boom mounted Wanderhose with Hydraulic power assist option.
- Water recirculation.

Nirosta® In My Body

- Complete Hopper Constructed of Stainless Steel
- We exclusively utilize Nirosta® Stainless Steel
- Better corrosion resistance than mild steel
- Abrasion resistance better than mild steel
- Abrasion resistance better than 304 stainless steel
- Complete Stainless Steel Water Tank
- Superior corrosion and abrasion resistance
- Lowest ownership costs and best warranties
- Only "Life-Time Warranty" in the industry

A comprehensive range of additional options is available. Please ask for details.

Johnston North America Inc.

606 A&B Performance Road • Mooresville, NC 28115

Tel: 704.658.1333 Fax: 704.658.1377

E-mail: info@johnstonnorthamerica.com • johnstonnorthamerica.com

Due to continuous product development Johnston North America reserves the right to alter specifications without prior notice. Copyright© 2014 Johnston North America Inc. VT801SPEC.0713

